

Magnetically Actuated Linear Position Sensor WIM100-Q25L141-LIU5X2-H1141

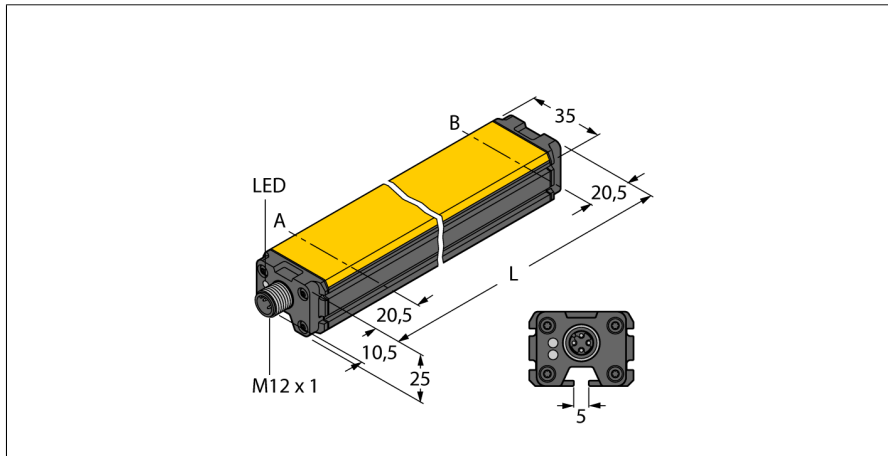

- Rectangular, aluminium / plastic
- Many mounting possibilities
- Measuring range indication via LED
- Immune to external magnetic fields
- Extremely short blind zones
- 4-wire, 15...30 VDC
- Analog output
- 0...10 V and 4...20 mA
- Male connector, M12 x 1

Wiring Diagram

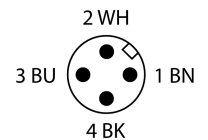
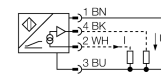

Type designation	WIM100-Q25L141-LIU5X2-H1141
Ident-No.	1536630
Measuring range [A...B]	100 mm
Resolution	0.1 mm/10 bit
Repeatability	≤ 0.1% of measuring range IA - BI ≤ depending on positioning element
Linearity deviation	≤ 1 %
Temperature drift	≤ ± 0.006 % / K
Ambient temperature	-25...+75 °C
Operating voltage	15...30 VDC
Residual ripple	≤ 10 % U _{ss}
Isolation test voltage	≤ 0.5 kV
Short-circuit protection	yes
Wire breakage/Reverse polarity protection	yes/ Complete
Output function	4-pin, Analog output
Voltage output	0...10V
Current output	4...20 mA
Load resistance voltage output	≥ 4.7 kΩ
Load resistance, current output	≤ 0.4 kΩ
Sample rate	200 Hz
Current consumption	< 50 mA
Design	Rectangular, Q25L
Dimensions	141 x 35 x 25 mm
Housing material	Aluminium
Active area material	Plastic, PA6-GF30
Electrical connection	Connector, M12 x 1
Vibration resistance	55 Hz (1 mm)
Shock resistance	30 g (11 ms)
Protection class	IP67
MTTF	131 years acc. to SN 29500 (Ed. 99) 40 °C
Packaging unit	1
Power-on indication	LED, Green
Measuring range display	LED, yellow, positioning element in measuring range

Functional principle

Linear position sensors operate on the Hall principle and accomplish simple control tasks. They provide an output signal proportional to the actuating magnet. The polarity of the magnet has no effect on the output signal. The outstanding features of these robust sensors are excellent repeatability, resolution and linearity, excellent electromagnetic capability and a broad temperature range.

Characteristic

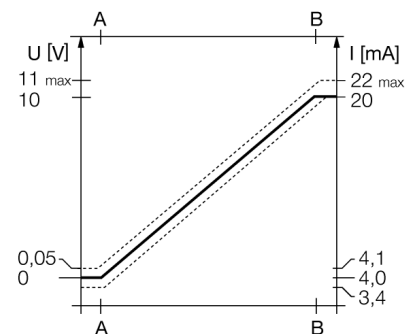

Magnetically Actuated Linear Position Sensor WIM100-Q25L141-LIU5X2-H1141

Mounting instructions/Description

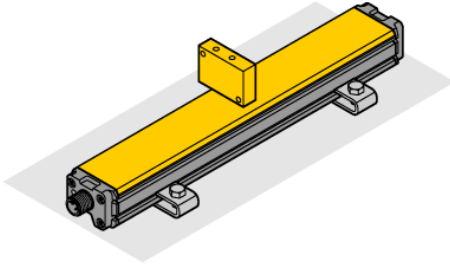

Numerous accessories allow the sensor to be mounted in various positions. Opposite to the active face, the sensor housing features a mounting groove for which sliding blocks are available. The lateral slot profiles can be used for mounting, too.

When used with an external positioning element, the sensor can either be mounted with the active face located opposite or laterally to the mounting surface. Drilling slots guarantee highest flexibility for fine adjustment.

The mounting accessories for linear position sensors can be adjusted to the respective cylinder sizes. The stainless steel accessories guarantee safe and robust mounting as well as highest flexibility. .

Magnetically Actuated Linear Position Sensor WIM100-Q25L141-LIU5X2-H1141

Accessories

Type code	Ident-No.	Description	
IM43-13-SR	7540041	Trip amplifier; 1-channel; input 0/4...20 mA or 0/2...10 V; supply of 2- or 3-wire transmitters/sensors; limit value adjustment via teach button; three relay outputs with one NO contact each; removable terminal blocks; 27 mm wide; universal voltage supply 20...250 VUC; further Limit value indicators are described in our "Interface Technology" catalog.	
M1-Q25L	6901045	Mounting foot for linear position sensor Q25L; aluminium; 2 pcs. per bag	
M2-Q25L	6901046	Mounting foot for linear position sensor Q25L; aluminium; 2 pcs. per bag	
MB1-Q25	6901026	Mounting clip for linear position sensor Q25L; material Stainless steel; 2 pcs. per bag	
MB2.1-Q25	6901027	Mounting bracket for linear position sensors Q25L; mounting on pneumatic cylinders (40...60mm); material: Stainless steel; 4 pcs. per bag	

Magnetically Actuated Linear Position Sensor

WIM100-Q25L141-LIU5X2-H1141

TURCK
works

Industrial
Automation

Accessories

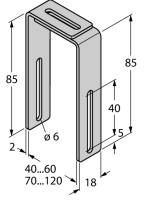
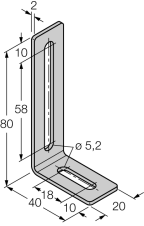
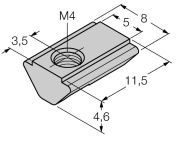
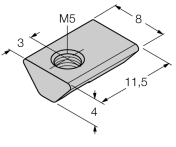
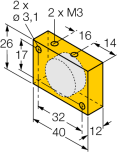
Type code	Ident-No.	Description	
MB2.2-Q25 (4 PCS)	6901028	Mounting bracket for linear position sensors Q25L; mounting on pneumatic cylinders (70...120mm); material: Stainless steel; 4 pcs. per bag	
M4-Q25L	6901048	Mounting bracket for linear position sensor Q25L; material Stainless steel; 2 pcs. per bag	
MN-M4-Q25	6901025	Sliding block with M4 thread for the backside profile of the Q25L; material: galvanized steel; 10 pcs. per bag	
MN-M5-Q25	6901039	Sliding block with M5 thread for the backside profile of the Q25L; material Stainless steel; 10 pcs. per bag	
DM-Q12	6900367	Actuation magnet; rectangular, plastic; attainable switching distance 58 mm on BIM-(E)M12 sensors resp. 49 mm on BIM-EG08 sensors; in combination with Q25L linear position sensors: recommended distance between the sensor and magnet: 3...5 mm	

Magnetically Actuated Linear Position Sensor

WIM100-Q25L141-LIU5X2-H1141



Accessories

Type code	Ident-No.	Description	
DMR15-6-3	6900216	Actuation magnet, \varnothing 15 mm (\varnothing 3 mm), h: 6 mm; sensing range 36 mm on BIM-(E)M12 sensors resp. 32 mm on BIM-EG08 sensors; in combination with Q25L: Recommended distance between sensor and magnet: 3 ... 4 mm	
DMR20-10-4	6900214	Actuation magnet; \varnothing 20 mm (\varnothing 4 mm), h: 10 mm; sensing range 59 mm on BIM-(E)M12 sensors resp. 50 mm on BIM-EG08 sensors; in combination with Q25L: Recommended distance between sensor and magnet: 3 ... 4 mm	
DMR31-15-5	6900215	Actuation magnet, \varnothing 31 mm (\varnothing 5 mm), h: 15 mm; sensing range 90 mm on BIM-(E)M12 sensors resp. 78 mm on BIM-EG08 sensors; in combination with Q25L: Recommended distance between sensor and magnet: 3 ... 5 mm	
P1-WIM-Q25L	6901088	Guided positioning element for WIM-Q25L, inserted in the sensor groove.	

Wiring accessories

Type code	Ident-No.	Description	
RKC4.4T-2/TEL	6625013	Connection cable, female M12, straight, 4-pin, cable length: 2 m, sheath material: PVC, black; cULus approval; other cable lengths and qualities available, see www.turck.com	

Magnetically Actuated Linear Position Sensor WIM100-Q25L141-LIU5X2-H1141



Wiring accessories

Type code	Ident-No.	Description	
RKC4.301T-0.15- RSC4.334T/TXL	6631382	Extension cable, M12 female/male, straight, 4-pin, cable length: 0.15m, jacket material: PUR, black; cULus approval; Adapter cable for sensors with analog output on pin 2, for connection to analog inputs of fieldbus modules with 4-wire technology	